

# 67 SERIES OIL-LESS ROTARY VANE VACUUM PUMPS & COMPRESSORS

## OPERATION & MAINTENANCE MANUAL



Model 2067-V103 Shown

Thank you for purchasing this Gast product. It is manufactured to the highest standards using quality materials. Please follow all recommended maintenance, operational and safety instructions and you will receive years of trouble free service.



### WARNING



**PLEASE READ THIS MANUAL COMPLETELY BEFORE INSTALLING AND USING THIS PRODUCT. SAVE THIS MANUAL FOR FUTURE REFERENCE AND KEEP IN THE VICINITY OF THE PRODUCT.**

#### Product Use Criteria:

- Pump only clean, dry air.
- Operate at 32°F - 104°F (0°C - 40°C).
- Protect unit from dirt & moisture.
- Do not pump flammable or explosive gases or use in an atmosphere that contains such gases.
- Protect all surrounding items from exhaust air. This exhaust air can become very hot.
- Corrosive gases and particulate material will damage unit. Water vapor, oil-based contaminants or other liquids must be filtered out.
- Consult your Gast Distributor/Representative before using at high altitudes.
- Oil-Less rotary-vanes require NO lubrication.
- Sealed bearings are grease packed.
- Use of petroleum or hydrocarbon products will reduce carbon vane service life.



ISO 9001 & 14001 CERTIFIED

[www.gastmfg.com](http://www.gastmfg.com)

**Your safety and the safety of others is extremely important.**

We have provided many important safety messages in this manual and on your product. Always read and obey all safety messages.

 This is the safety alert symbol. This symbol alerts you to hazards that can kill or hurt you and others. The safety alert symbol and the words “DANGER” and “WARNING” will precede all safety messages. These words mean:

## DANGER

You will be killed or seriously injured if you don't follow instructions.

## WARNING

You can be killed or seriously injured if you don't follow instructions.

## INSTALLATION

### WARNING



#### Electrical Shock Hazard

Disconnect electrical power at the circuit breaker or fuse box before installing this product.

Install this product where it will not come into contact with water or other liquids.

Install this product where it will be weather protected.

Electrically ground this product.

Failure to follow these instructions can result in death, fire or electrical shock.

**Correct installation is your responsibility.** Make sure you have the proper installation conditions and that installation clearances do not block air flow. Proper guards should be installed to prevent contact with moveable parts of this pump. Do Not lift the unit by the fan shroud.

**Blocking air flow over the product in any way can cause the product to overheat. Mounting**

This product can be installed in any orientation. Mounting the product to a stable, rigid operating surface and using shock mounts will reduce noise and vibration

#### Plumbing

Remove plugs from the IN and OUT ports. Connect with pipe and fittings that are the same size or larger than the product's threaded ports.

#### Accessories

The product's internal intake and exhaust filters will provide adequate filtration in most applications. Check filters periodically and replace when necessary. All units should have an intake and exhaust filter to prevent contaminants from entering the pump or the pneumatic system. Please consult your Gast Distributor/Representative for additional filter recommendations.

Install relief valves and gauges at inlet or outlet, or both, to monitor performance. Check valves may be required to prevent back streaming through the pump.

#### Motor Control

It is your responsibility to contact a qualified electrician to assure that the electrical installation is adequate and in conformance with all national and local codes and ordinances.

Determine the correct overload setting required to protect the motor (see motor starter manufacturer's recommendations). Select fuses, motor protective switches or thermal protective switches to provide protection. Fuses act as short circuit protection for the motor, not as protection against overload. Incoming line fuses help to withstand the motor's starting current. Motor starters with thermal magnetic overload or circuit breakers protect motor from overload or reduced voltage conditions.

The wiring diagram supplied with the product provides required electrical information. Check that power source is correct to properly operate the dual-voltage motors.

#### Electrical Connection

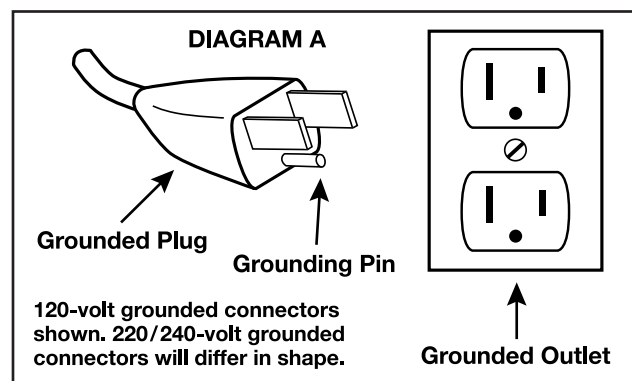

**Model with a power supply cord:**

This product must be grounded. For either 120-volt or 220/240-volt circuits connect power supply cord grounding plug to a matching grounded outlet. Do not use an adapter. (See DIAGRAM A)

In the event of an electrical short circuit, grounding reduces the risk of electric shock by providing an escape wire for the electric current. This product may be equipped with a power supply cord having a grounding wire with an appropriate grounding plug. The plug must be plugged into an outlet that is properly installed and grounded in accordance with all local codes and ordinances.

**Check with a qualified electrician or serviceman if the grounding instructions are not completely understood, or if you are not sure whether the product is properly grounded. Do not modify the plug provided. If it will not fit the outlet, have the proper outlet installed by a qualified electrician.**

**Model that is permanently wired:**

This product must be connected to a grounded, metallic, permanent wiring system, or an equipment grounding terminal or lead on the product.

Power supply wiring must conform to all required safety codes and be installed by a qualified person. Check that supply voltage agrees with that listed on product nameplate.

**Extension cords:**

Use only a 3-wire extension cord that has a 3-blade grounding plug. Connect extension cord plug to a matching 3-slot receptacle. Do not use an adapter. Make sure your extension cord is in good condition. Check that the gage wire of the extension cord is the correct size wire to carry the current this product will draw.

Minimum gage for extension cords										
Amps	Volts	Length of cord in feet								
	120v	25	50	100	150	200	250	300	400	500
	240v	50	100	200	300	400	500	600	800	1000
0-2		18	18	18	16	16	14	14	12	12
2-3		18	18	16	14	14	12	12	10	10
3-4		18	18	16	14	12	12	10	10	8
4-5		18	18	14	12	12	10	10	8	8
5-6		18	16	14	12	10	10	8	8	8
6-8		18	16	12	10	10	8	6	6	6
8-10		18	14	12	10	8	8	6	6	4
10-12		16	14	10	8	8	6	6	4	4
12-14		16	12	10	8	6	6	6	4	2
14-16		16	12	10	8	6	6	4	4	2
16-18		14	12	8	8	6	4	4	2	2
18-20		14	12	8	6	6	4	4	2	2

**OPERATION**

 **WARNING**

**Injury Hazard**

**Install proper safety guards as needed. Pumps with glass jars need safety guards to protect against breaking glass.**

**Use only recommended air handling parts acceptable for pressure not less than 70 psi.**

**Keep fingers and objects away from openings and rotating parts.**

**When provided, motor terminal covers must be in place for safe operation.**

**Check that coupling guard and shroud are in place before operating.**

**Product surfaces may become hot during operation, allow product surfaces to cool before handling.**

**Do NOT direct air stream at body. Air stream from product may contain solid or liquid material that can result in eye or skin damage, wear proper eye protection.**

**Do NOT spray flammable or combustible liquid.**

**Wear hearing protection. Sound level from motor may exceed 85 dBA.**

**Failure to follow these instructions can result in burns, eye injury or other serious injury.**

**It is your responsibility to operate this product at recommended pressures or vacuum duties and room ambient temperatures. Do Not start against a vacuum or pressure load.**

**Start Up**

If motor fails to start or slows down significantly under load, shut off and disconnect from power supply. Check that the voltage is correct for motor and that motor is turning in the proper direction. Vane life will be drastically reduced if motor is not operating properly. Vanes can break or be damaged if motor/pump runs in the wrong direction.

 **WARNING**



**Electrical Shock Hazard**

**Disconnect electrical power supply cord before performing maintenance on this product.**

**If product is hard wired into system, disconnect electrical power at the circuit breaker or fuse box before performing maintenance on this product.**

**Failure to follow these instructions can result in death, fire or electrical shock.**



## WARNING

### Injury Hazard

Product surfaces become very hot during operation, allow product surfaces to cool before handling.

Do NOT direct air stream at body. Air stream from product may contain solid or liquid material that can result in eye or skin damage, wear proper eye protection.

Clean this product in a well ventilated area.

Failure to follow these instructions can result in burns, eye injury or other serious injury.

It is your responsibility to:

- Regularly inspect and make necessary repairs to product in order to maintain proper operation.
- Make sure that pressure and vacuum is released from product before starting maintenance.

Check intake and exhaust filters after first 500 hours of operation. Clean filters and determine how frequently filters should be checked during future operation. **This one procedure will help to assure the product's performance and service life.**

Clean filters when necessary by removing and washing in a solvent or soap and water. After cleaning, dry with compressed air to make sure all moisture is removed before replacing filters.

### Flushing

Flushing this product to remove excessive dirt, foreign particles, moisture or oil that occurs in the operating environment will help to maintain proper vane performance. If your pump is not getting the vacuum or pressure level expected, flushing is required. Vanes will stick when dirty and may cause pump to be noisy or inefficient.

Use only Gast recommended flushing solvent or other non-petroleum based flushing solvent. Do Not use kerosene or ANY other combustible solvent to flush product.

1. Disconnect electrical power supply.
2. Release all pressure and vacuum from pump.
3. Remove all accessories at the inlet and exhaust ports.
4. Remove filter.
5. Start product. Place towel over exhaust port to clean up solvent. If using liquid solvent, pour several tablespoons directly into inlet port. If using Gast recommended spray solvent, spray for 5-10 seconds into inlet port.
6. Block the inlet port and draw a deep vacuum for 15-20 seconds. Release the vacuum.
7. Listen for changes in the sound of the motor. If motor sounds smooth, go to next step. If motor does not sound like it is running smoothly, repeat steps 5 and 6 until you can hear a difference in the operating sound of the pump.
8. Start the pump and let it run for 1 minute, then turn pump off.
9. Replace all accessories at the inlet and exhaust ports.
- 4 10. Replace filter before resuming operation.

Check that all external accessories such as relief valves and gauges are attached to cover and are not damaged before re-operating product.

## SHUTDOWN PROCEDURES

It is your responsibility to follow proper shutdown procedures to prevent product damage.

### NEVER ADD OIL TO THIS OIL-LESS PUMP.

Proper shutdown procedures must be followed to prevent pump damage. Failure to do so may result in premature pump failure. The Gast Manufacturing Rotary Vane Oil-Less Vacuum Pumps and Compressors are constructed of ferrous metals or aluminum which are subject to rust and corrosion when pumping condensable vapors such as water. Follow the steps below to assure correct storage and shutdown between operating periods

1. Disconnect plumbing.
2. Operate product for at least 5 minutes without plumbing.
3. Run at maximum vacuum for 10-15 minutes.
4. Repeat step 2.
5. Disconnect power supply.
6. Plug open ports to prevent dirt or other contaminants from entering product.

## SERVICE KIT INSTALLATION



## WARNING

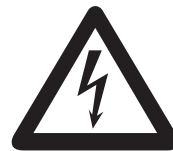

### Electrical Shock Hazard

Disconnect electrical power supply cord before installing service kit.

If product is hard wired into system, disconnect electrical power at the circuit breaker or fuse box before installing service kit.

Disconnect air supply and vent all air lines to release pressure or vacuum.

Failure to follow these instructions can result in death, fire or electrical shock.

Gast will NOT guarantee field-rebuilt product performance. For performance guarantee, the product must be returned to a Gast Authorized Service Facility.

Service Kit contents vary. Most contain vanes, gaskets and filter parts.

Do Not attempt to remove the rotor. It is held in place by Loctite and can only be serviced by a Gast Authorized Service Facility.

Do Not loosen or adjust motor thru-bolts to prevent misalignment and damage to the pump.

## Disassembly

1. Remove two fan/coupling guard screws. Remove guard.
2. Remove four motor bolts. Remove motor.
3. Loosen two set screws in coupling flange. Remove coupling flange from drive end shaft.
4. Remove four screws from the dead end fan guard. Remove guard. Use a pulley puller to remove fan.
5. Remove eight dead end plate bolts with the special adapter tool.
6. Use a small hammer to carefully tap on dead end plate to remove. Do Not use a screwdriver.
7. Remove the dowel pins from the body and dead end plate.
8. Remove vanes. If vanes are stuck, use needle nose pliers to help loosen and remove vanes.
9. Use snap ring pliers to remove snap ring.
10. Remove Belleville springs, flat washer, bearing and deflector. Note how items are placed for reassembly.
11. Place unit with the drive end shaft in an upright position on a protected surface. Remove rotor.
12. Use an adjustable spanner wrench or a special adapter tool to remove drive end cap, bearing and deflector from drive end plate.

**Do Not disassemble any further parts. The factory has determined the exact top and overall end clearances. Further disassembly will change these settings.**

## Cleaning

1. Clean all parts with solvent and remove all solvent from parts.
2. Use a 12" smooth file on the faces of end plates and body to remove burrs.
3. Use file to carefully clean out vane slots in rotor.
4. Use emery cloth to clean and remove burrs from body bore and rotor outside diameter.
5. Clean filed parts again with solvent then remove all solvent from parts.

## Reassembly

1. Place drive end plate on shim aligning bolt holes.
2. Install eight drive end bolts by hand. Do Not tighten at this time.
3. Drive two dowel pins into body through drive end plate.
4. Torque bolts to 75-125 in. lbs.
5. Place rotor with drive end up in a fixture on an arbor press.
6. Place body and drive end plate assembly over shaft so that drive end plate is on the face of rotor.
7. Place deflector and bearing on shaft and slide both down to bearing journal.
8. Use bearing pusher and arbor press to press bearing down all the way. Bearing pusher must make contact with both inner and outer race of bearing.

9. Flip unit over so the dead end is up.
10. Install vanes into rotor.
11. Replace dead end plate over shaft and body aligning bolt holes.
12. Place deflector and bearing on shaft and slide both down to bearing journal.
13. Drive two dowel pins into body through drive end plate.
14. Torque bolts to 75-125 in. lbs.
15. Place large cupped end of one Belleville spring down against the outer bearing race. Place a flat washer on top of Belleville spring.
16. Use snap ring pliers to place snap ring over Belleville spring and press into groove in dead end plate.
17. Secure a dial indicator onto dead end shaft to check axial movement. Push in indicator to allow for a free travel of .01" to the rear.
18. Install drive end cap onto drive end plate. Hand tighten until end cap bottoms out on bearing.
19. Tighten drive end cap with a spanner wrench or a special adapter tool until drive end cap is tight. Dial indicator should move back to .007" or .0075" for the 2067/2567 Series models, .0049" to .0055" for the 1567 Series model and .0035" to .004" for the 1067 Series model to assure proper clearance. If reading does not fall into range for the model in question, disassemble and add or remove shims until proper clearance range is achieved.
20. Remove drive end cap and apply several drops of Loctite 222 to threads. Replace drive end cap and tighten. Check with factory for clearances.
21. Press dead end cooling fan on and center it so it will not hit dead end plate or fan guard.
22. Replace dead end fan guard and attach with four bolts.
23. Replace drive end coupling on drive end shaft. Tighten set screws.
24. Place motor on motor bracket and attach with four motor bolts.
25. If motor is 3-phase, check that motor rotates properly.
26. Push motor coupling flange against coupling sleeve until tight. Tighten set screws in motor coupling flange.
27. Replace coupling fan guard and attach with two guard bolts.



### Replacing New Body or Rotor

1. Use a micrometer to read the rotor length and body thickness. Subtract rotor length from body thickness. Check with Factory for clearances.
2. For desired rotation, the inlet port needs to be to the left of the body for counter-clockwise rotation or to the right for clockwise rotation.
3. If gasket is needed, place one or more gaskets on body face.
4. Place rotor through body bore.
5. Place drive end plate on body gasket.
6. Install all screws and hand tighten.
7. Place motor with drive down in fixture and apply pressure to hold against drive end plate.
8. Place a .003" shim between rotor and body bore. Tap body toward or away from rotor until shim is snug and resists being moved.
9. Tighten bolts at the 9:00 and 3:00 o'clock positions.

10. Release shaft and rotate rotor to next position. Check rotor lobe. Set each clearance to the tightest setting. Repeat until all lobes have been checked.
11. Remove from fixture and tighten remaining screws.
12. Either leave dowel pins out or drill new dowel pin holes and use new dowel pins. **Do Not re-use old dowel pins.**

**Check that all external accessories such as relief valves and gauges are attached to cover and are not damaged before re-operating product.**

**If pump still does not produce proper vacuum or pressure, send unit to a Gast Authorized Service Facility for repair.**



### Disposal (Please note current regulations)

Parts of the rotary vane pumps and compressors, shafts, iron or aluminum castings, plastic or glass parts or bearings, may be recycled as scrap materials.

## EXPLODED PRODUCT VIEW, PARTS & ORDERING INFORMATION

For the following exploded view, please reference Series and Model parts chart on facing page.

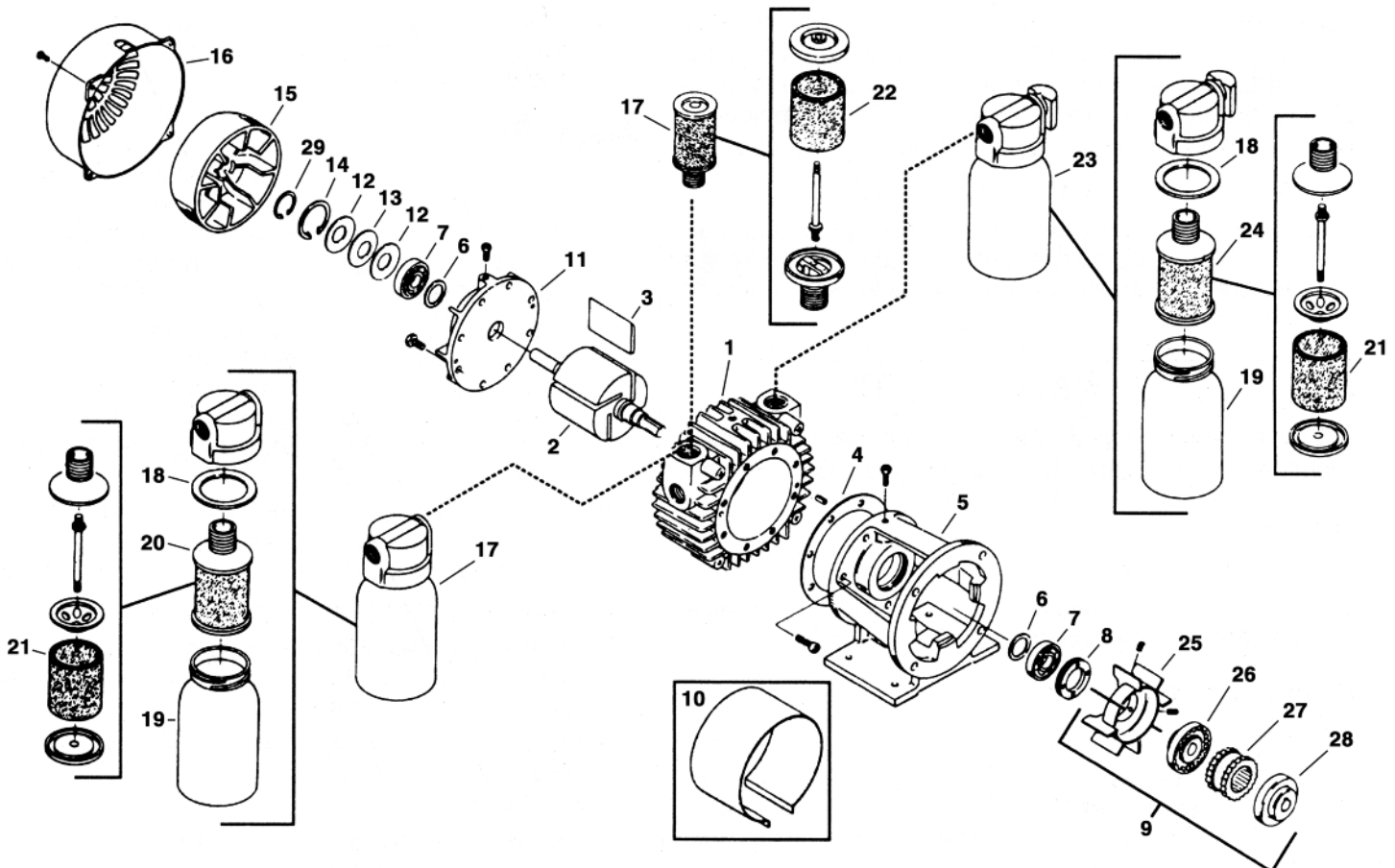

	PRODUCT SERIES Pump or Compressor Model #		SERIES 1067 Vacuum Pump 1067-V103	SERIES 1067 Compressor 1067-P102	SERIES 1567 1567-101	SERIES 2067 Vacuum Pump 2067-V103	SERIES 2067 Compressor 2067-P102	SERIES 2567 Vacuum Pump 2567-V103	SERIES 2567 Compressor 2567-P102
REF	DESCRIPTION	QTY							
1	BODY	1	AH345	AH345	AH291	AH191	AH191	AH355	AH355
2	ROTOR ASSEMBLY	1	AH428	AH428	AH292	AH192	AH192	AH192	AH192
3 Δ	VANE	4	AH430	AH430	AB125B	AH195	AH195	AH195	AH195
4 Δ	BODY GASKET	1	AH567	AH567	AH567	AH567	AH567	AH567	AH567
5	FOOT BRACKET	1	AH208	AH208	AH208A	AH208	AH208	AH208	AH208
6 Δ	DEFLECTOR	2	AH193	AH193	AH193A	AH193	AH193	AH193	AH193
7 Δ	BALL BEARING (Drive & Dead)	2	AC894	AC894	AC894	AC894	AC894	AC894	AC894
8	END CAP, DRIVE	1	AB339	AB339	AB339	AB339	AB339	AB339	AB339
9	FAN COUPLING ASSEMBLY	1	-	-	AH198-1	AH198-1	AH198-1	AH198-1	AH198-1
10	FAN GUARD	1	AH194	AH194	AH194	AH194	AH194	AH194	AH194
11	END PLATE, DEAD	1	AH205	AH205	AH205B	AH205	AH205	AH205	AH205
12	BELLEVILLE SPRINGS	2	AB337	AB337	AB337	AB337	AB337	AB337	AB337
13	WASHER	1	AB338	AB338	AB338	AB338	AB338	AB338	AB338
14	SNAP RING	1	AB335	AB335	AB335	AB335	AB335	AB335	AB335
15	FAN	1	AC326B	AC326B	AC326B	AC326B	AC326B	AC326B	AC326B
16	FAN GUARD	1	AC102C	AC102C	AC102C	AC102C	AC102C	AC102C	AC102C
17	INTAKE FILTER ASSEMBLY	1	AA800C	AA905F	-	AA900D	AA905G	AA900D	AA905G
18	GASKET	2	AA405	-	-	AA405	-	AA405	-
19	JAR	2	AA401	-	-	AA401	-	AA401	-
20	FILTER ASSEMBLY	1	AC434-1	-	-	AC435-1	-	AC435-1	-
21 Δ	CARTRIDGE	2	AC393	-	-	AC393	-	AC393	-
22 Δ	FILTER FELT	1	-	D344B	-	-	D344B	-	D344B
23	MUFFLER	1	AA800F	-	-	AA900F	-	AA900F	-
24	MUFFLER ASSEMBLY	1	AC434-1	-	-	AC436-1	-	AC436-1	-
25	FAN	1	AH197	AH197	AH197	AH197	AH197	AH197	AH197
26	FLANGE	1	AH196	AH196	AH196	AH196	AH196	AH196	AH196
27	SLEEVE	1	AE546	AE546	AE546	AE546	AE546	AE546	AE546
28	FLANGE	1	AE545B	AE545B	AE546B	AE545B	AE545B	AE545B	AE545B
29	RETAINER RING	1	AC447	AC447	AC447	AC447	AC447	AC447	AC447
	SERVICE KIT	1	K356	K356	K897	K350	K357	K350	K357

Δ Denotes parts included in the Service Kit.

Parts listed are for stock models. For specific OEM models, please consult the factory.

When corresponding or ordering parts, please give complete model and serial numbers.

## WARRANTY

Gast finished products, when properly installed and operated under normal conditions of use, are warranted by Gast to be free from defects in material and workmanship for a period of twelve (12) months from the date of purchase from Gast or an authorized Gast Representative or Distributor. In order to obtain performance under this warranty, the buyer must promptly (in no event later than thirty (30) days after discovery of the defect) give written notice of the defect to Gast Manufacturing Incorporated, PO Box 97, Benton Harbor Michigan USA 49023-0097 or an authorized Service Center (unless specifically agreed upon in writing signed by both parties or specified in writing as part of a Gast OEM Quotation). Buyer is responsible for freight charges both to and from Gast in all cases.

This warranty does not apply to electric motors, electrical controls, and gasoline engines not supplied by Gast. Gast's warranties also do not extend to any goods or parts which have been subjected to misuse, lack of maintenance, neglect, damage by accident or transit damage.

THIS EXPRESS WARRANTY EXCLUDES ALL OTHER WARRANTIES OR REPRESENTATIONS EXPRESSED OR IMPLIED BY ANY LITERATURE, DATA, OR PERSON. GAST'S MAXIMUM LIABILITY UNDER THIS EXCLUSIVE REMEDY SHALL NEVER EXCEED THE COST OF THE SUBJECT PRODUCT AND GAST RESERVES THE RIGHT, AT ITS SOLE DISCRETION, TO REFUND THE PURCHASE PRICE IN LIEU OF REPAIR OR REPLACEMENT.

GAST WILL NOT BE RESPONSIBLE OR LIABLE FOR INDIRECT OR CONSEQUENTIAL DAMAGES OF ANY KIND, however arising, including but not limited to those for use of any products, loss of time, inconvenience, lost profit, labor charges, or other incidental or consequential damages with respect to persons, business, or property, whether as a result of breach of warranty, negligence or otherwise. Notwithstanding any other provision of this warranty, BUYER'S REMEDY AGAINST GAST FOR GOODS SUPPLIED OR FOR NON-DELIVERED GOODS OR FAILURE TO FURNISH GOODS, WHETHER OR NOT BASED ON NEGLIGENCE, STRICT LIABILITY OR BREACH OF EXPRESS OR IMPLIED WARRANTY IS LIMITED SOLELY, AT GAST'S OPTION, TO REPLACEMENT OF OR CURE OF SUCH NONCONFORMING OR NON-DELIVERED GOODS OR RETURN OF THE PURCHASE PRICE FOR SUCH GOODS AND IN NO EVENT SHALL EXCEED THE PRICE OR CHARGE FOR SUCH GOODS. GAST EXPRESSLY DISCLAIMS ANY WARRANTY OF MERCHANTABILITY OR FITNESS FOR A PARTICULAR USE OR PURPOSE WITH RESPECT TO THE GOODS SOLD. THERE ARE NO WARRANTIES WHICH EXTEND BEYOND THE DESCRIPTIONS SET FORTH IN THIS WARRANTY, notwithstanding any knowledge of Gast regarding the use or uses intended to be made of goods, proposed changes or additions to goods, or any assistance or suggestions that may have been made by Gast personnel.

Unauthorized extensions of warranties by the customer shall remain the customer's responsibility.

CUSTOMER IS RESPONSIBLE FOR DETERMINING THE SUITABILITY OF GAST PRODUCTS FOR CUSTOMER'S USE OR RESALE, OR FOR INCORPORATING THEM INTO OBJECTS OR APPLICATIONS WHICH CUSTOMER DESIGNS, ASSEMBLES, CONSTRUCTS OR MANUFACTURES.

This warranty can be modified only by authorized Gast personnel by signing a specific, written description of any modifications.

**TROUBLESHOOTING CHART**

Low		High		Pump Overheat	Motor Overload	Reason and remedy for problem.
Vacuum	Pressure	Vacuum	Pressure			
•	•	At pump		•	•	Filter dirty. Clean or replace.
	•		At pump	•	•	Muffler dirty. Clean or replace.
•		At pump		•	•	Vacuum line collapsed. Repair or replace.
•			•	•	•	Relief valve set too high. Inspect and adjust.
•	•					Relief valve set too low. Inspect and adjust.
•	•	At pump	At pump	•	•	Plugged vacuum/pressure line. Inspect and repair.
•	•					Vanes sticking. Clean or replace.
•	•					Vanes worn. Replace.
•	•					Shaft seal worn. Replace.
•	•			•	•	Dust or offset powder in pump. Inspect and clean.
•	•			•		Motor not wired correctly. Check wiring diagram and line voltage.
		•	•	•	•	Running at too high an RPM. Check wiring diagram and line voltage.

We have Gast Authorized Repair Facilities throughout the world. For the most up-to-date listing, contact one of our sales offices below:

**Gast Manufacturing, Inc.**  
 2300 S. Highway M139  
 Benton Harbor, MI 49022  
 Ph: 269/926-6171  
 FAX: 269/925-8288  
 www.gastmfg.com

**Gast Group Limited, United Kingdom**  
 Unit 11, The I O Centre  
 Nash Road  
 Redditch, B98 7AS  
 United Kingdom  
 ph: +44 (0) 1527 504040  
 Fax: +44 (0) 1527 525262  
 www.gastmfg.com

**Gast Hong Kong**  
 Room 6, 9F  
 New Commerce Centre  
 19 On Sum St., Shatin  
 N. T. Hong Kong  
 Ph: (852) 2690 1066  
 Fax: (852) 2690 1012  
 www.gasthk.com



ISO 9001 & 14001 CERTIFIED

www.gastmfg.com