

Oil-less Rotary Vane 6066 Series Vacuum Pumps and Compressors

Operation & Maintenance Manual



6066-V 103 Model Shown



6066 B60 Model Shown

GAST

A UNIT OF IDEX CORPORATION

Dear Customer:

Thank you for purchasing this Gast product. It is manufactured to the highest standards using quality materials. Please follow all recommended maintenance, operational, and safety instructions, and you will receive years of trouble-free service.



 WARNING	
	PLEASE READ THIS MANUAL COMPLETELY BEFORE INSTALLING AND USING THIS PRODUCT. SAVE THIS MANUAL FOR FUTURE REFERENCE AND KEEP IN THE VICINITY OF THE PRODUCT.

TABLE OF CONTENTS

Product Use and Criteria	3
General Information	3
Mounting	4
Plumbing	4
Accessories	4
Motor Control	4
Operation	6
Start Up	6
Maintenance	6
Shutdown Procedures	7
Service Kit Installation	8
Parts and Ordering Information	10
Warranty	11
Troubleshooting Chart	12

PRODUCT USE AND CRITERIA

- Pump only clean, dry air.
- Operate at 32 °F to 104 °F (0 °C to 40 °C).
- Protect unit from dirt and moisture.
- Do not pump flammable or explosive gases or use in an atmosphere that contains such gases.
- Protect all surrounding items from exhaust air. This exhaust air can become very hot.
- Corrosive gases and particulate material will damage unit. Water vapor, oil-based contaminants, or other liquids must be filtered out.
- Consult your Gast Distributor before using at high altitudes.
- Oil-less rotary-vanes require NO lubrication.
- Sealed bearings are grease packed.
- Use of petroleum or hydrocarbon products will reduce carbon-vane service life.

GENERAL INFORMATION

Model numbers ending in "X" have automatic thermal protectors which protect the motor by shutting the motor off if it overheats. The motor will automatically restart once the motor has cooled.

Your safety and the safety of others is extremely important.

We have provided many important safety messages in this manual and on your product. Always read and obey all safety messages.



This is the safety alert symbol. This symbol alerts you to hazards that can kill or hurt you and others. The safety alert symbol and the words "DANGER" and "WARNING" will precede all safety messages. These words mean:

 DANGER

You will be killed or seriously injured if you don't follow instructions.

 WARNING

You can be killed or seriously injured if you don't follow instructions.

All safety messages will identify the hazard, tell you how to reduce the chance of injury, and tell you what can happen if the safety instructions are not followed.

INSTALLATION

 WARNING

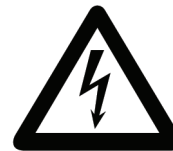

Electrical Shock Hazard

Disconnect electrical power at the circuit breaker or fuse box before installing this product.

Install this product where it will not come into contact with water or other liquids.

Install this product where it will be weather protected.

Electrically ground this product.

Failure to follow these instructions can result in death, fire, or electrical shock.

Correct installation is your responsibility.

Make sure you have the proper installation conditions and that installation clearances do not block air flow. Proper guards should be installed to prevent contact with moveable parts of this pump. Do not lift the unit by the fan shroud.



CAUTION: The unit should be lifted by means of the eye bolt.



WARNING: Blocking air flow over the product in any way can cause the product to overheat.

Some models are equipped with glass jars. Proper measures should be taken to guard against the fragmenting or braking of glass if an alternative material is not used. If hazard is ignored severe personal injury or death can occur.

Mounting

This product can be installed in any orientation. Mounting the product to a stable, rigid operating surface and using shock mounts will reduce noise and vibration.

Plumbing

Remove plugs from the IN and OUT ports. Connect with pipe and fittings that are the same size or larger than the product's threaded ports.

Accessories

The product's internal intake and exhaust filters will provide adequate filtration in most applications. Check filters periodically and replace when necessary. All units should have an intake and exhaust filter to prevent contaminants from entering the pump or the pneumatic system. Please consult your Gast Distributor/Representative for additional filter recommendations.

Install relief valves and gauges at inlet or outlet, or both, to monitor performance. Check valves may be required to prevent back streaming through the pump.

Motor Control

It is your responsibility to contact a qualified electrician to assure that the electrical installation is adequate and in conformance with all national and local codes and ordinances.

Determine the correct overload setting required to protect the motor (see motor starter manufacturer's recommendations). Select fuses, motor protective switches, or thermal protective switches to provide protection. Fuses act as short circuit protection for the motor, not as protection against overload. Incoming line fuses help to withstand the motor's starting current. Motor starters with thermal magnetic overload or circuit breakers protect motor from overload or reduced voltage conditions.

The wiring diagram supplied with the product provides required electrical information. Check that power source is correct to properly operate the dual-voltage motors.

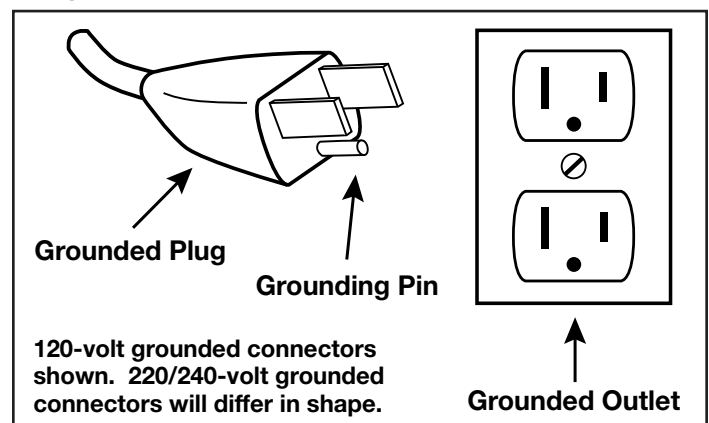
Electrical Connection Diagram A

Model with a power supply cord:

This product must be grounded. For either 120-volt or 220/240-volt circuits connect power supply cord grounding plug to a matching grounded outlet. Do not use an adapter. (See Diagram A)

In the event of an electrical short circuit, grounding reduces the risk of electric shock by providing an escape wire for the electric current. This product may be equipped with a power supply cord having a grounding wire with an appropriate grounding plug. The plug must be plugged into an outlet that is properly installed and grounded in accordance with all local codes and ordinances.

Check with a qualified electrician or serviceman if the grounding instructions are not completely understood, or if you are not sure whether the product is properly grounded. Do not modify the plug provided. If it will not fit the outlet, have the proper outlet installed by a qualified electrician.

Model that is permanently wired:

This product must be connected to a grounded, metallic, permanent wiring system, or an equipment grounding terminal or lead on the product.

Power supply wiring must conform to all required safety codes and be installed by a qualified person. Check that supply voltage agrees with that listed on product nameplate.

Be sure the 3-phase motor turns in the proper direction of rotation after installation. Turning in the wrong direction will drastically reduce vane life.

Extension cords:

Use only a 3-wire extension cord that has a 3-blade grounding plug. Connect extension cord plug to a matching 3-slot receptacle. Do not use an adapter. Make sure your extension cord is in good condition. Check that the gage wire of the extension cord is the correct size wire to carry the current this product will draw.

Minimum gage for extension cords										
Amps	Volts	Length of cord in feet								
	120v	25	50	100	150	200	250	300	400	500
	240v	50	100	200	300	400	500	600	800	1000
0-2		18	18	18	16	16	14	14	12	12
2-3		18	18	16	14	14	12	12	10	10
3-4		18	18	16	14	12	12	10	10	8
4-5		18	18	14	12	12	10	10	8	8
5-6		18	16	14	12	10	10	8	8	8
6-8		18	16	12	10	10	8	6	6	6
8-10		18	14	12	10	8	8	6	6	4
10-12		16	14	10	8	8	6	6	4	4
12-14		16	12	10	8	6	6	6	4	2
14-16		16	12	10	8	6	6	4	4	2
16-18		14	12	8	8	6	4	4	2	2
18-20		14	12	8	6	6	4	4	2	2

OPERATION

 **WARNING**

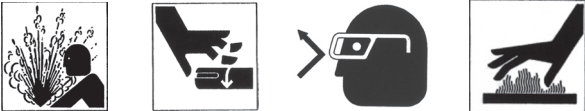

Injury Hazard

Install proper safety guards as needed. Pumps with glass jars need safety guards to protect against breaking glass.

Use only recommended air handling parts acceptable for pressure not less than 70 psi.

Keep fingers and objects away from openings and rotating parts.

When provided, motor terminal covers must be in place for safe operation.

Check that coupling guard and shroud are in place before operating.

Product surfaces may become hot during operation, allow product surfaces to cool before handling.

Do not direct air stream at body. Air stream from product may contain solid or liquid material that can result in eye or skin damage, wear proper eye protection.

Do not spray flammable or combustible liquid.

Wear hearing protection. Sound level from product may exceed 85 dBA.

Failure to follow these instructions can result in burns, eye injury or other serious injury.

It is your responsibility to operate this product at recommended pressures or vacuum duties and room ambient temperatures. Do not start against a vacuum or pressure load.

Start Up

If motor fails to start or slows down significantly under load, shut off and disconnect from power supply. Check that the voltage is correct for motor and that motor is turning in the proper direction. Vane life will be drastically reduced if motor is not operating properly. Vanes can break or be damaged if motor/pump runs in the wrong direction.

MAINTENANCE

 **WARNING**



Electrical Shock Hazard

Disconnect electrical power supply cord before performing maintenance on this product.

If product is hard wired into system, disconnect electrical power at the circuit breaker or fuse box before performing maintenance on this product.

Failure to follow these instructions can result in death, fire, or electrical shock.

 **WARNING**



Injury Hazard

Wear eye protection when flushing this product.

Air stream from product may contain solid or liquid material that can result in eye or skin damage.

Flush this product in a well ventilated area.

Do not use kerosene or other combustible solvents to flush this product.

Failure to follow these instructions can result in eye injury or other serious injury.

It is your responsibility to:

- **Regularly inspect and make necessary repairs to product in order to maintain proper operation.**
- **Make sure that pressure and vacuum is released from product before starting maintenance.**

Check intake and exhaust filters after first 500 hours of operation. Clean filters and determine how frequently filters should be checked during future operation. This one procedure will help to assure the product's performance and service life.

Clean filters when necessary by removing and washing in a solvent or soap and water. After cleaning, dry with compressed air to make sure all moisture is removed before replacing filters.

Flushing

Flushing this product to remove excessive dirt, foreign particles, moisture, or oil that occurs in the operating environment will help to maintain proper vane performance. If your pump is not getting the vacuum or pressure level expected, flushing is required. Vanes will stick when dirty and may cause pump to be noisy or inefficient.

Use only Gast-recommended solvent or other non-petroleum based flushing solvent. Do not use kerosene or ANY other combustible solvent to flush product.

1. Disconnect electrical power supply.
2. Release all pressure and vacuum from pump.
3. Remove all accessories at the inlet and exhaust ports.
4. Remove filter.
5. Start product. Place towel over exhaust port to clean up solvent. Spray Gast recommended solvent for 5-10 seconds into inlet port.
6. Block the inlet port and draw a deep vacuum for 15-20 seconds. Release the vacuum.
7. Listen for changes in the sound of the motor. If motor sounds smooth, go to next step. If motor does not sound like it is running smoothly, repeat steps 5 and 6 until you can hear a difference in the operating sound of the pump.
8. Start the pump and let it run for 1 minute, then turn pump off.
9. Replace all accessories at the inlet and exhaust ports.
10. Replace filter before resuming operation.

Check that all external accessories such as relief valves and gauges are attached to cover and are not damaged before re-operating product.

SHUTDOWN PROCEDURES

It is your responsibility to follow proper shutdown procedures to prevent product damage. NEVER ADD OIL TO THIS OIL-LESS PUMP.

Proper shutdown procedures must be followed to prevent pump damage. Failure to do so may result in premature pump failure. The Gast Manufacturing Rotary Vane Oil-Less Vacuum Pumps and Compressors are constructed of ferrous metals or aluminum which are subject to rust and corrosion when pumping condensable vapors such as water. Follow the steps below to assure correct storage and shutdown between operating periods.

1. Disconnect plumbing.
2. Operate product for at least 5 minutes without plumbing.
3. Run at maximum vacuum for 10-15 minutes.
4. Repeat step 2.
5. Disconnect power supply.
6. Plug open ports to prevent dirt or other contaminants from entering product.

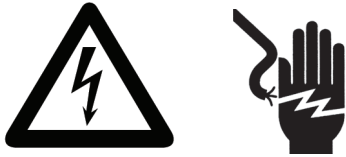
SERVICE KIT INSTALLATION**! WARNING****Electrical Shock Hazard**

Disconnect electrical power supply cord before installing Service Kit.

If product is hard wired into system, disconnect electrical power at the circuit breaker or fuse box before installing Service Kit.

Disconnect air supply and vent all air lines to release pressure in vacuum.

Failure to follow these instructions can result in death, fire, or electrical shock.

Gast will NOT guarantee field-rebuilt product performance. For performance guarantee, the product must be returned to a Gast Authorized Service Facility.

Service Kit contents vary. Most contain vanes, gaskets, and filter parts.

Do not attempt to remove the rotor. It is held in place by Loctite and can only be serviced by a Gast Authorized Service Facility.

Do not loosen or adjust motor thru-bolts to prevent misalignment and damage to the pump.

Disassembly:

1. Remove the dead end shroud, fan, and fan spacer.
2. Use a wheel puller to remove the dead-end plate and bearing from the pump body. Note the direction of the bevel edge on the vane. Do not damage the dowel pins between the end plate and the body. Save the bearing spacer on the dead-end of the shaft for reassembly. Remove the snap ring from the end plate. Save the snap ring, Belleville springs, and washer for reassembly.
3. Remove the bearing from the dead-end plate.
4. Check the exposed surfaces of the rotor, body, and end plate for scoring. If you find no scoring, you can perform a Minor Rebuild to replace only the vanes and the dead-end bearing. If you find severe damage, perform the Major Rebuild. Remove two retainer plate screws on retainer plate (may require heat to break adhesive on retainer screws) and discard old cup.

Minor Rebuild:

1. Follow Disassembly steps 1-4.
2. Install the new vanes supplied with the kit. Be careful to face the vane bevels in the proper direction (as noted in Disassembly, step 2).
3. Place end plate over the shaft with dowel pins aligned. Place bearing spacer on dead end of shaft. Place the new bearing in its bore in the dead end plate. Be careful to press only on the inner bearing race.
4. Install and tighten the pump body bolts, install the Belleville springs with the washer between them and the snap ring.

Major Rebuild:

1. Follow Disassembly steps 1-4.
2. Remove the drive end cap. Use a wheel puller to remove the drive-end plate and bearing from the body. Do not remove or damage the dowel pins in the body. Save the bearing spacer and end plate gasket for reassembly.
3. Place one shoulder ring in its seat in the drive-end plate, then place one of the new bearings in the seat. Using an arbor press, press the bearing onto the shaft. Be careful to press only on the inner bearing race. Tighten the pump body bolts.
4. Install the new vanes supplied with the kit. Be careful to face the vane bevels in the proper direction (as noted in step 2).
5. Perform step #3 from Minor Rebuild.
6. Install the belleville springs with the washer between them and the snap ring. Install and tighten the pump body bolts.
7. Apply a thread-lock adhesive and start the drive-end cap into its thread in the drive-end plate, but do not tighten it.
8. Place a dial indicator against the dead-end of the shaft to measure axial movement. Tighten the drive-end cap until the indicator shows: 0.002 in to 0.003 in of shaft movement against the belleville springs.
9. Clean and reinstall filter(s).

EXPLODED VIEW, PARTS, AND ORDERING INFORMATION

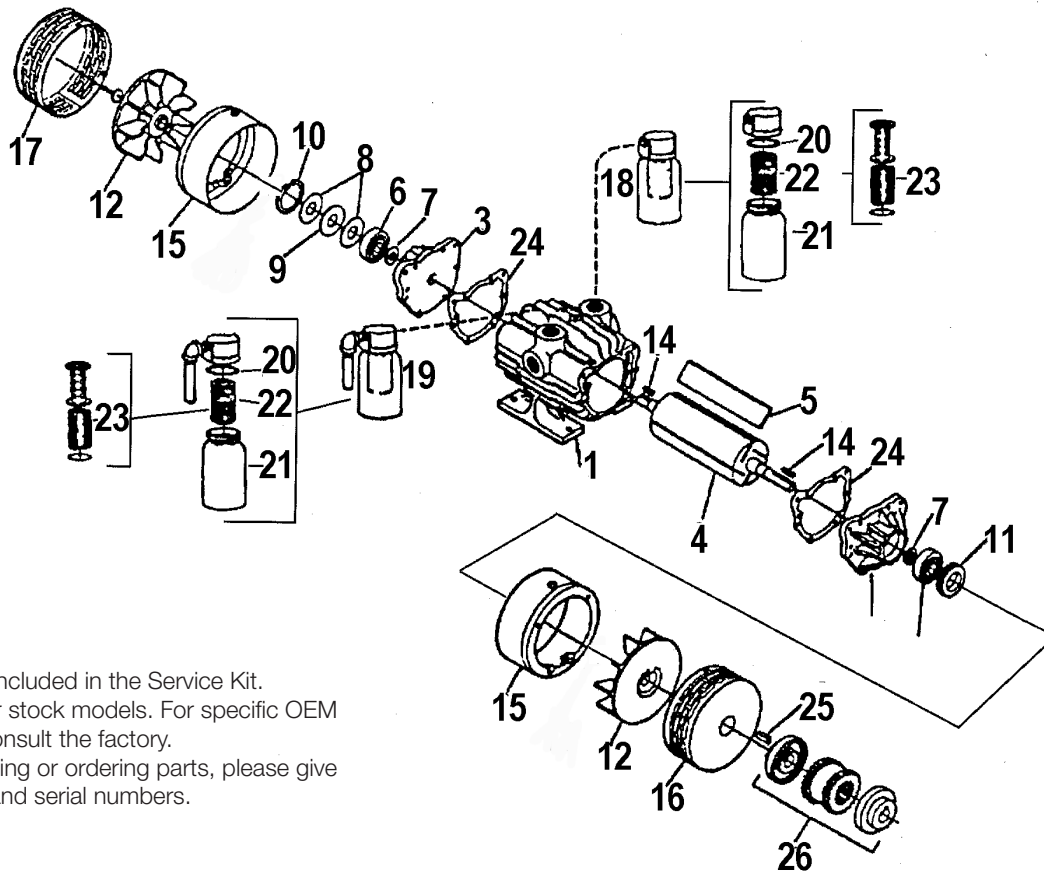

Δ Denotes parts included in the Service Kit.
 Parts listed are for stock models. For specific OEM models, please consult the factory.
 When corresponding or ordering parts, please give complete model and serial numbers.

REF	DESCRIPTION	QTY	6066-P102	6066-V103
1	BODY	1	AC309	AC309
2	DRIVE END PLATE	1	AE293	AE293
3	DEAD END PLATE	1	AE294	AE294
4	ROTOR ASSEMBLY	1	AE295A	AE295A
5 Δ	VANE	4	AK738	AK738
6 Δ	BEARING	2	AB964B	AB964B
7	BEARING SHOULDER RING	2	AB926T	AB926T
8	BELLEVILLE SPRING	2	AB791	AB791
9	SHIM WASHER	1	AB792	AB792
10	RETAINING RING	1	AB793	AB793
11	END CAP	1	AB790	AB790
12	FAN	2	AL443	AL443
14	SQUARE KEY	2	AB136A	AB136A
15	SHROUD	2	AE300A	AE300A
16	FAN GUARD ASSM, DRIVE	1	AK736	AK736
17	IFAN GUARD ASSM, DEAD	1	AK737	AK737
18	INTAKE FILTER ASSEMBLY	1	AD560	AD560
19	MUFFLER ASSEMBLY	1	-	AD560C
20 Δ	COVER GASKET	1	AD562	-
		2	-	AD562
21	JAR	1	AD563A	-
		2	-	AD563A
22	FILTER ELEMENT ASSEMBLY	1	AD750	-
		2	-	AD750
23 Δ	FILTER FELT	1	AD752	-
		2	-	AD752
24	BODY SPACER	1	AE315B	-
		2	-	AE315B
25	KEY, COUPLING	1	AE136D	AE136D
26	COUPLING ASSEMBLY	1	AE765	AE765
27	CHECK VALVE (NOT SHOWN)	1	AH326B	AH326B
***	SERVICE KIT (NOT SHOWN)	1	K503	K503

WARRANTY POLICY

Gast finished products, when properly installed and operated under normal conditions of use, are warranted by Gast to be free from defects in material and workmanship for a period of twelve (12) months from the date of purchase from Gast or an authorized Gast Representative or Distributor. In order to obtain performance under this warranty, the buyer must promptly (in no event later than thirty (30) days after discovery of the defect) give written notice of the defect to Gast Manufacturing Incorporated, PO Box 97, Benton Harbor Michigan USA 49023-0097 or an authorized Service Center (unless specifically agreed upon in writing signed by both parties or specified in writing as part of a Gast OEM Quotation). Buyer is responsible for freight charges both to and from Gast in all cases.

This warranty does not apply to electric motors, electrical controls, and gasoline engines not supplied by Gast. Gast's warranties also do not extend to any goods or parts which have been subjected to misuse, lack of maintenance, neglect, damage by accident or transit damage.

THIS EXPRESS WARRANTY EXCLUDES ALL OTHER WARRANTIES OR REPRESENTATIONS EXPRESSED OR IMPLIED BY ANY LITERATURE, DATA, OR PERSON. GAST'S MAXIMUM LIABILITY UNDER THIS EXCLUSIVE REMEDY SHALL NEVER EXCEED THE COST OF THE SUBJECT PRODUCT AND GAST RESERVES THE RIGHT, AT ITS SOLE DISCRETION, TO REFUND THE PURCHASE PRICE IN LIEU OF REPAIR OR REPLACEMENT.

GAST WILL NOT BE RESPONSIBLE OR LIABLE FOR INDIRECT OR CONSEQUENTIAL DAMAGES OF ANY KIND, however arising, including but not limited to those for use of any products, loss of time, inconvenience, lost profit, labor charges, or other incidental or consequential damages with respect to persons, business, or property, whether as a result of breach of warranty, negligence or otherwise. Notwithstanding any other provision of this warranty, BUYER'S REMEDY AGAINST GAST FOR GOODS SUPPLIED OR FOR NON-DELIVERED GOODS OR FAILURE TO FURNISH GOODS, WHETHER OR NOT BASED ON NEGLIGENCE, STRICT LIABILITY OR BREACH OF EXPRESS OR IMPLIED WARRANTY IS LIMITED SOLELY, AT GAST'S OPTION, TO REPLACEMENT OF OR CURE OF SUCH NONCONFORMING OR NON-DELIVERED GOODS OR RETURN OF THE PURCHASE PRICE FOR SUCH GOODS AND IN NO EVENTS SHALL EXCEED THE PRICE OR CHARGE FOR SUCH GOODS. GAST EXPRESSLY DISCLAIMS ANY WARRANTY OF MERCHANTABILITY OR FITNESS FOR A PARTICULAR USE OR PURPOSE WITH RESPECT TO THE GOODS SOLD. THERE ARE NO WARRANTIES WHICH EXTEND BEYOND THE DESCRIPTIONS SET FORTH IN THIS WARRANTY, notwithstanding any knowledge of Gast regarding the use or uses intended to be made of goods, proposed changes or additions to goods, or any assistance or suggestions that may have been made by Gast personnel.

Unauthorized extensions of warranties by the customer shall remain the customer's responsibility.

CUSTOMER IS RESPONSIBLE FOR DETERMINING THE SUITABILITY OF GAST PRODUCTS FOR CUSTOMER'S USE OR RESALE, OR FOR INCORPORATING THEM INTO OBJECTS OR APPLICATIONS WHICH CUSTOMER DESIGNS, ASSEMBLES, CONSTRUCTS OR MANUFACTURES.

This warranty can be modified only by authorized Gast personnel by signing a specific, written description of any modifications.

TROUBLESHOOTING CHART

Low		High		Pump Overheat	Motor Overload	Reason and remedy for problem
Vacuum	Pressure	Vacuum	Pressure			
x	x	at pump		x	x	Filter dirty. Clean or replace.
	x		at pump		x	Muffler dirty. Clean or replace.
x		at pump		x	x	Vacuum line collapsed. Repair or replace.
x			x	x	x	Relief valve set too high. Inspect and adjust.
x	x					Relief valve set too low. Inspect and adjust.
x	x	at pump	at pump	x	x	Plugged vacuum/pressure line. Inspect and repair.
x	x					Vanes sticking. Clean or replace.
x	x					Vanes worn. Replace.
x	x					Shaft seal worn. Replace.
x	x			x	x	Dust or offset powder in pump. Inspect and clean.
x	x			x		Motor not wired correctly. Check wiring diagram/line voltage.
		x	x	x	x	Running at too high an RPM. Check wiring diagram/line voltage.

For repair parts ordering information and exploded product view, visit our website or call us at the number listed below.

We have Gast Authorized Repair Facilities throughout the world. For the most up-to-date listing, contact one of our sales offices below:

Gast Manufacturing

P.O. Box 97
2300 M139 Highway
Benton Harbor, MI 49023-0097
Ph: 269-926-6171
Fax: 269-925-8288
www.gastmfg.com

Gast Group Limited

c/o IDEX Trading (Shanghai) Co., LTD
Room 3502-3505
No. 1027 Chang Ning Road,
Zhaofeng Plaza
Shanghai, China 200050
Phone +86-21-52415599
Fax +86-21-52418339

Gast Group Ltd.

Unit 11, The I O Centre
Nash Road
Redditch, B98 7AS
United Kingdom
Phone +44 (0)1527-504040
Fax +44 (0)1527-525262

GAST

A UNIT OF IDEX CORPORATION

www.gastmfg.com