

# DRY SPRINKLER COMPRESSOR

## RISER & FLOOR MOUNT CAPABLE

A quiet, easy to install, air compressor unit for fire sprinkler applications

# GAST®

*A wide range  
of pressure and  
system capacity  
all in one unit*



### FULLY ADJUSTABLE, EASY TO SET DIGITAL PRESSURE SWITCH

| PRESSURE (PSI) | SYSTEM CAPACITY (GALLONS) |
|----------------|---------------------------|
| 10             | 1350                      |
| 12             | 1110                      |
| 14             | 950                       |
| 16             | 825                       |
| 18             | 725                       |
| 20             | 650                       |
| 22             | 580                       |
| 24             | 530                       |
| 26             | 490                       |
| 28             | 450                       |
| 30             | 415                       |
| 32             | 385                       |
| 34             | 360                       |
| 36             | 335                       |
| 38             | 315                       |
| 40             | 300                       |

SCAN FOR PRODUCT  
INFORMATION PAGE



WWW.GASTMFG.COM

P/N: 87R-100S

**GAST MANUFACTURING, INC.**

A Unit of IDEX Corporation

2300 M-139 Highway, Benton Harbor, MI 49022

Office: 941-416-0252 | Tech: 269-934-1296

Copyright © IDEX Corporation 2021. Gast is a unit of IDEX Corporation.

## SUPERIOR COMPRESSOR TECHNOLOGY

Gast oil-less **rocking piston** technology leads the way for dry sprinkler compressors in many ways. Our U.S. based design and manufacturing features internal baffling for **ultra quiet operation**, industrial grade shock mounts for low vibration, and highly engineered cup seal materials for **industry leading compressor life**. Oil-less operation means lower maintenance and the compact twin-cylinder design needs no separate drive belts, is lighter weight, and **easier to service** than lubricated compressors.

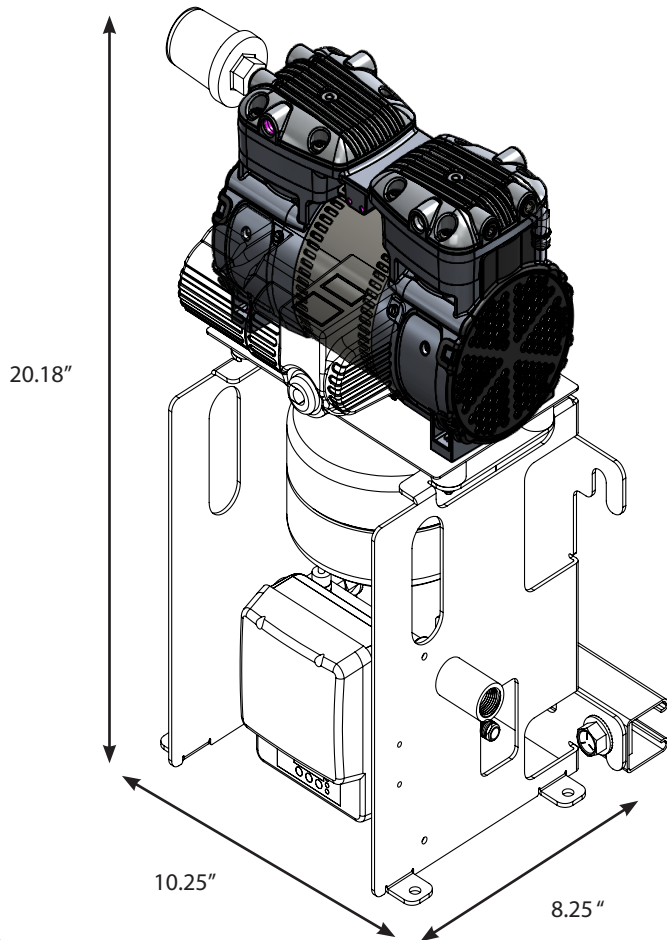

## EASY TO INSTALL



Mount bracket using pipe clamp



Hang system on bracket



Secure lower pipe clamp

### HARDWARE INCLUDED

- Pipe Clamps for Mounting
- 24" Connecting Hose
- Inlet Filter

### OPTIONAL FLOOR MOUNT KIT PN: K1022



To convert riser mount to floor placement.

# GAST®

| MODEL NUMBER | AMPS | HP  | KW   | NET WEIGHT |    | VOLT  | FREQ. |
|--------------|------|-----|------|------------|----|-------|-------|
|              |      |     |      | lbs.       | kg |       |       |
| 87R-100S     | 6.0  | 1/2 | 0.37 | 42         | 19 | 120 v | 60 Hz |